

ANTI-MODE 8033 User's Manual

Revision History

Rev.	Date	Author	Affected chapters	Description
1.0	30.11.2007	TK & ToLi	All	Original version Finnish and English
1.1	13.12.2007	TK	5	Updated input sensitivity level
1.2	7.1.2008	TK	6	www.dspeaker.com
1.3	18.1.2008	ToLi	2	Input level warning leds / converter delay
1.4	19.3.2008	ToLi	All	Typo fixes, chapter 2.1 reflex advice added, chapter 7 added
1.5	3.4.2008	TK	All	Reformatted, added power consumption to Ch 8.
1.6	8.1.2010	POj	All	C-version graphics, some parts rewritten
1.7	9.11.2010	POj	All	S version added, recycling and other information added

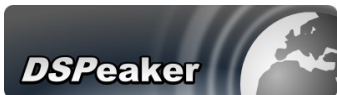

ANTI-MODE 8033

Recycling information

The product you have purchased is marked according to the **Waste Electrical and Electronic Equipment Directive** (WEEE Directive). There are take-back systems in place that help to preserve nature and natural resources when products are disposed of appropriately. If you need to dispose of this product, use the take-back system that has dedicated collection facilities for electronic equipment. Do not put the product into household waste disposal!



Also, the product has been manufactured using parts and processes that follow the directive of the Restriction of the use of certain Hazardous Substances in Electrical and Electronic Equipment (RoHS).

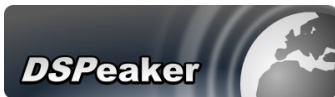

Table of contents

1. Connections and buttons	4
1.1. Front panel:.....	4
1.2. Back Panel.....	5
2. Quick setup guide	6
2.1. Before calibration.....	6
2.2. Calibration.....	7
2.3. After calibration.....	7
3. Wider area correction	8
3.1. Strategy 1, "Compensation of the weakest point":.....	8
3.2. Strategy 2, "Gradient compensation":.....	9
4. Basic operation	10
4.1. Bypass mode.....	10
4.2. Lifting EQ.....	10
4.2.1. "Flat".....	10
4.2.2. Lifting 15-25Hz.....	10
4.2.3. Lifting 25-35Hz.....	10
4.3. Bridging.....	11
4.4. ADC level warning.....	11
4.5. Powering Up and Down.....	11
5. Technical specification	12
6. Manufacturer	12
7. Support	12

ANTI-MODE 8033 User's Manual

1. Connections and buttons

1.1. Front panel:

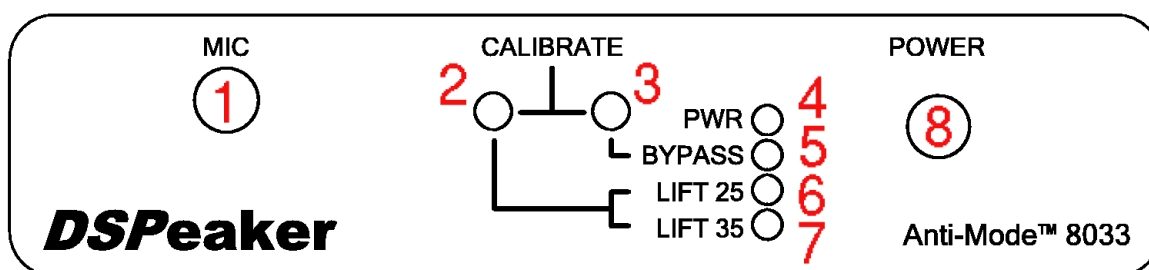

Figure 1: ANTI-MODE 8033C Front panel

1. Microphone input jack
2. Button A: LIFT 25 / LIFT 35 / FLAT selector
Short press: Selects low frequency boost
Long press: Store current low frequency boost setting
3. Button B: BYPASS
Short press: Disable/enable processing
Long press: Begin second-phase calibration for wide area correction
Buttons A & B simultaneously long press: Begin calibration
4. PWR LED: Lit when the device is on
5. BYPASS LED: Lit when bypassed
6. LIFT 25 LED: Lit when 15-25Hz lifting EQ and subsonic filter is on
7. LIFT 35 LED: Lit when 25-35Hz lifting EQ and subsonic filter is on
8. POWER switch: Switches power on/off **(in Anti-Mode 8033C)**



Figure 2: ANTI-MODE 8033S Front panel

1.2. Back Panel

Anti-Mode 8033C

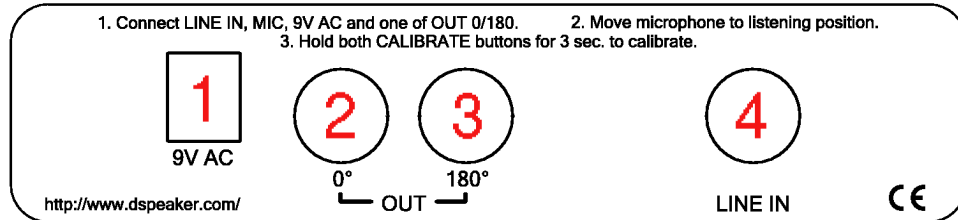

Figure 3: ANTI-MODE 8033C rear panel

1. 9V AC connector: Input power. Note: Anti-Mode 8033C needs AC voltage!
2. OUT 0-connector: In-phase RCA out (default)
3. OUT 180-connector: Out-of-phase RCA out
OUT0 and OUT180 connectors can be used for bridged operation of stereo amplifier
4. LINE IN-connector: Line input (subwoofer pre-out signal from pre-amplifier or A/V receiver)

Anti-Mode 8033S



Figure 4: ANTI-MODE 8033S rear panel

1. 9V AC / 12V DC connector: Input power.
2. OUT 180 connector: Out-of-phase RCA out
3. OUT 0 connector: In-phase RCA out (default)
OUT0 and OUT180 connectors can be used for bridged operation of stereo amplifier or create balanced XLR output with an adapter cable
4. LEFT LINE IN connector: Line input (subwoofer pre-out signal from pre-amplifier or A/V receiver)
5. RIGHT LINE IN connector: Line input (subwoofer pre-out signal from pre-amplifier or A/V receiver)

The dual LEFT / RIGHT inputs can be used to connect stereo systems that have only stereo pre-amplifier outputs instead of a single LFE output. You can also connect your home theater LFE output to the LEFT input and stereo system to the RIGHT input using the stereo to mono summing cable.

2. Quick setup guide

1. Connect the subwoofer signal pre-out to "LINE IN" (LEFT input in 8033S).
2. Connect the active subwoofer to "OUT 0" output.
3. Connect microphone plug to "MIC" jack and fix the microphone as close to the listening position (head of the listener) as possible.
4. Connect the power supply to "9V AC" connector and wall socket.
5. Switch ANTI-MODE 8033 on (Anti-Mode 8033S will turn on automatically when you plug it in).

Note: All the leds on front panel are lit if the device has never been calibrated

6. Switch on the subwoofer and leave its volume setting unaltered

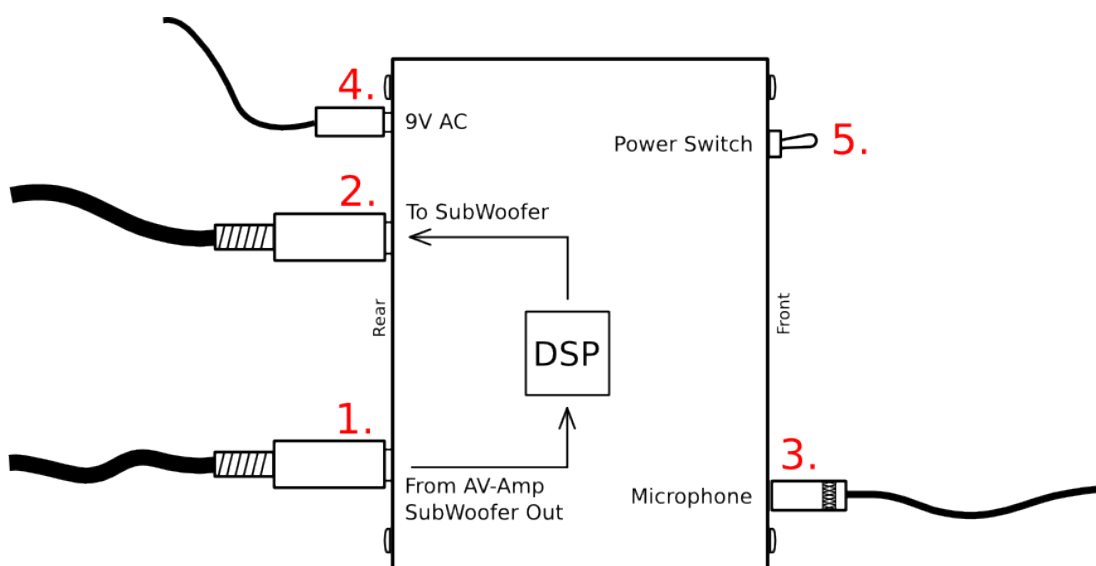
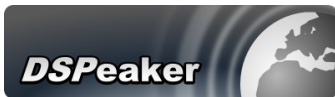

Figure 5: Setting up ANTI-MODE 8033

2.1. Before calibration

With small reflex subwoofers, it is advised to decrease their volume before calibration. If the subwoofer has a built-in low-pass or other type of filter, it should be deactivated during calibration process. It can be re-activated after calibration. Cross-over and low-pass filters at the A/V receiver do not affect calibration, since they take place before Anti-Mode 8033 in the signal chain. Also any other audio equipment that may affect subwoofer signal prior to the Anti-Mode 8033 do not interfere with the calibration process. As room modes may have strong dependency of the position, it is advisable to also pay attention to the vertical positioning (height) of the calibration microphone. The microphone is omnidirectional, so its precise orientation doesn't matter. If you want the room correction to affect a wider area, the first calibration point should be selected near the center of this area (or the primary listening position). More about wider area correction in the latter section "Wider area correction".



2.2. Calibration

Press both buttons at the front panel and hold them for about three seconds. Make sure that both of the buttons are pressed and held. After about three seconds the middle LED will start flashing and calibration begins. You may now release the buttons and wait for the automatic calibration to finish. The measurement program analyzes the room four times with a frequency sweep.

During the calibration, the device will adjust the output level automatically. If the microphone level in is too loud, it is automatically decreased. The calibration is quite robust, so it tolerates certain amount of background noise, hence speech and small noises do not distract the process. However, one should avoid making loud noises, especially near the microphone.

If you initiate calibration by mistake, you can abort it by turning off the unit (Anti-Mode 8033C), or by pressing either button after a few seconds of calibration (Anti-Mode 8033S).

2.3. After calibration

Once the last sweep is over, the calibration is finished. The results are stored in the non-volatile memory inside the unit, so they are not lost even when Anti-Mode loses power. The Anti-Mode 8033 is now fully functional and the microphone can be detached, unless the user wishes to perform wider area calibration.

After calibration the subwoofer may sound more quiet than before. This is because the room resonances have been suppressed. Typically, the subwoofer volume needs to be increased slightly (3-10 dB).

If the A/V receiver supports speaker distances, you can add 90 cm to the subwoofer distance relative to other speakers to compensate for the internal processing delay. This is not absolutely necessary since the delay is small enough that the human auditory system can generally not detect it.

You can also use your A/V receiver's automatic functions to determine the correct distance and level settings. In that case the processing latency of Anti-Mode is automatically taken into account by the A/V receiver. The speaker setting "small" should be used for best results.

Attention! If for some reason only one sweep signal was generated during the calibration, both buttons at the front panel were not pressed. In this case, the calibration process must be re-initialized.

Whenever the placement of the subwoofer or listening position changes, the calibration should be performed again to assure optimal result.

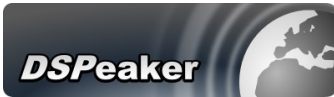

3. Wider area correction

In some situations it is more favourable to compensate the room acoustics for a larger area. In this case, the result is no longer optimal in any single listening position, but generally improved for a wider area. Before wider area correction, the normal calibration procedure described in the earlier section must be performed. The initial calibration is done with the microphone at the center of the listening area (or primary listening position within the area).

Anti-Mode 8033 is calibrated to larger area by taking the microphone to some other point within the listening area. Pressing and holding button B, bypass (Figure 1, object 3) will initiate a single additional frequency sweep. Anti-Mode 8033 will use it in conjunction with the data gathered at the first calibration to create a compensation model for a larger listening area within the room.

Do not accidentally press and keep both buttons at the front panel, as this will start main calibration all over again and overrides the current room data.

Wider area calibration can be done multiple times and it does not lose the data from the main calibration. Thus it is easy to try different second phase calibration points for the best audible result. There are several strategies in choosing the microphone position for second phase calibration.

3.1. Strategy 1, “Compensation of the weakest point”:

When the first (main) calibration is performed to the primary listening position or to the center of the listening area, one can already evaluate the result by listening it at different positions. If the result is not adequate at some location, this spot could be used as a second phase calibration point. Also any location between this point and the first point can lead to good results. Inevitably, the result will get less optimal in the first point, but usually improved a lot everywhere else including the weakest point.

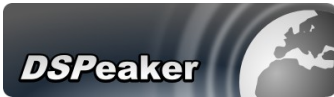

3.2. Strategy 2, “Gradient compensation”:

When the first (main) calibration is performed to the primary listening position or to the center of the listening area, but it is difficult to find the weakest point within the listening area, gradient compensation is a good approach. Second phase calibration point for wider area correction can be found by taking the microphone from first calibration point toward the closest corner of the listening room by 40-90 cm and down (toward the floor) approximately 10-20 cm. Wider area calibration second phase will be performed to this achieved position. If the first (main) calibration point was in close proximity of walls (distance less than 1m.) , the microphone should be moved only about 20-40 cm toward that wall for second phase calibration. Gradient compensation method usually works well in removing the axial modes for larger area in rectangular room.

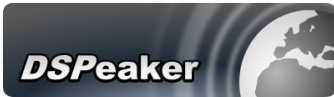

4. Basic operation

4.1. Bypass mode

If you want to compare the corrected and uncorrected operation, press the Bypass button shortly. This will switch between bypass and normal mode. The first press will put Anti-Mode into bypass mode, which is also indicated by the “Bypass” LED (Figure 1, object 5) on. If the Bypass mode is already active, the unit switches to normal mode instead. In bypass mode, no room corrections are active. Also the user selected lifting EQ is turned off.

4.2. Lifting EQ

The Lifting EQ button rotates between three equalization modes of Anti-Mode 8033 and stores the setting if held longer. A brief sound is heard from subwoofer when the setting is stored.

4.2.1. “Flat”

The first lifting EQ setting is no lifting, “flat.” Neither of the LEDs 'LIFT 25' nor 'LIFT 35' is lit. In this setting, the target response is flat from 5 to 148 Hz.

4.2.2. Lifting 15-25Hz

In lifting 15-25 mode, when the LED “LIFT 25” is lit, the Anti-Mode will boost frequencies between 15 and 25 Hz (max. 7dB at 20Hz). This will also activate digital infasonic filter, which will filter out frequencies below 10Hz, that can be dangerous to ported subs without proper protection.

4.2.3. Lifting 25-35Hz

Third mode, lifting 25-35 similarly boosts range 25-35 Hz (max. 7dB at 30Hz) on subwoofer. This mode is active when the LED LIFT 35 is on. This will also activate digital infasonic filter, which will filter out frequencies below 10Hz.

It is easiest to find out which of the lifting settings gives best result by simply listening. Lifting below 35Hz could be useful for reflex subwoofers, which have port tuning above 30Hz, but the lowest frequencies are attenuated to the listening position. With music, 'flat' is probably the best option, as it gives the most accurate transient response. Lifting below 25Hz could be applicable for a large subwoofer, which has -6dB point too high because of suboptimal positioning.

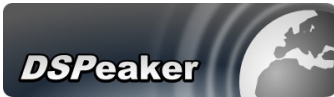

4.3. Bridging

Bridging is always done with user's own responsibility and consideration, as not all stereo amplifiers can provide bridged operation. Ordinary stereo amplifier can be bridged by using both OUT-0 and OUT-180 RCA outputs. (Figure 2, objects 2 and 3.). Using differential output will give 2.83 times the amplification of a single output channel. In bridging + poles of both the output channels of the power amplifier are used instead of + and -. Bridging is useful as means of multiplying the power of stereo amplifier used for passive subwoofer.

4.4. ADC level warning

If the input signal level in AD-converter is close to the input sensitivity maximum value, the user is warned about this in two phases. If the input signal level has only 3 dB of headroom, the "Bypass" led will start flickering. If the input level reaches maximum, the "lift 25" led will start flashing (independent of whether these leds were lit in the first place or not). If the input signal is higher than maximum value of ADC, the signal is saturated to avoid clipping.

The ADC level warning is useful in optimizing the input signal level that goes into Anti-Mode.

The level warning is not active during calibration. During calibration the output level is decreased automatically if needed, and the flashing LED is used to indicate the progress of calibration.

4.5. Powering Up and Down

Anti-Mode 8033C

Turn on Anti-Mode from the power switch before your subwoofer and power down subwoofer before turning off Anti-Mode. Because Anti-Mode consumes very little power, you may also choose to leave it on permanently.

Anti-Mode 8033S

Anti-Mode 8033S has almost completely eliminated power-on and power-off transients, so you can easily power it on and off using a switchable power cord or power output from your Audio-Video receiver. Anti-Mode also fades in the signal when it starts, so it can be powered on even while audio signal is already applied to the input connector(s).

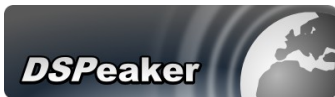

ANTI-MODE 8033

5. Technical specification

Electrical characteristics:

Power consumption	1.2 W (from 9V AC)	
Input sensitivity:	Line level (max 1.75 Vrms)	
	8033C	8033S
Operation voltage:	9V AC	9V AC or 12 V DC
Frequency range (-3 dB):	5 – 160 Hz	5 – 240 Hz
Low-pass:	Bessel 12 dB/octave, Q ~ 0.5	
	fc = 160Hz	fc = 240 Hz
Amplification:	3.5 dB	3.0 dB
Dynamic ratio (unweighted):	90 dB	>92dB

Firmware features:

Anti-Mode-Filters:	24 pcs.
Correction range:	16 - 144 Hz
Frequency resolution:	< 0.5 Hz
Maximum attenuation:	96 dB
Filter Q-value range:	Unlimited (32-bit integer space)
Sub-sonic-filter:	10 Hz (user selectable)
Computation accuracy:	32/40-bit integer

6. Manufacturer



VLSI Solution Oy / DSPeaker Division
Hermiankatu 8 B
FIN-33720 Tampere
FINLAND
Fax: +358-3-3140-8288
Tel: +358-3-3140-8200
Email: sales@vlsi.fi
URL: <http://www.dspeaker.com/>

7. Support

support@dspeaker.com
info@dspeaker.com